

Aluminium 2×1 Rail

Aluminium 2×1 Rail

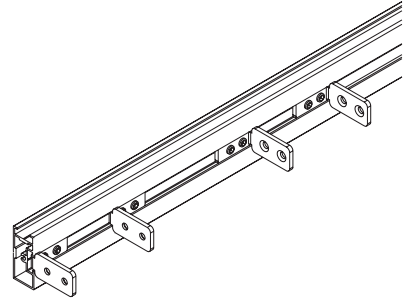
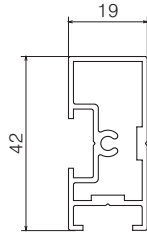
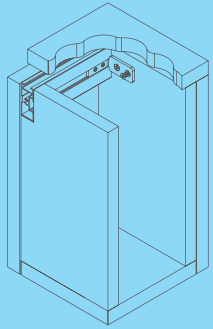

Cat No.	Length (mm)	Finish
2380. 31. 042	3700*	white, powder coated
2380. 38. 042	3700*	clear anodized
2380. 39. 042	3700*	black anodized

Packing: 6pcs

* Usable length 3630~3670mm

Fixing Method

Flat

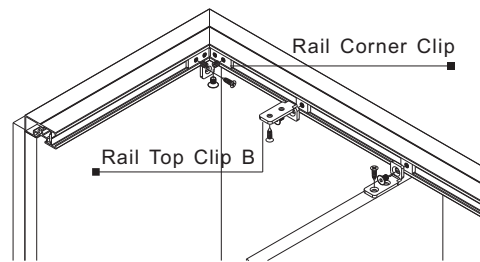

Inverted

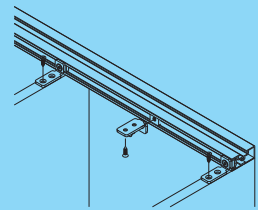
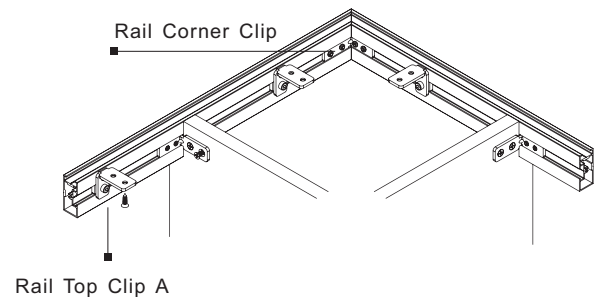
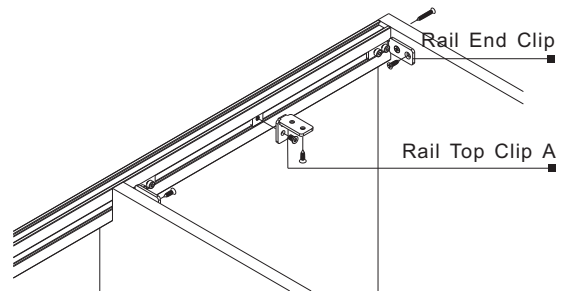

Dimensional Data not binding.
We reserve the right to alter specifications without notice.

Aluminium 2×1 Rail Clips

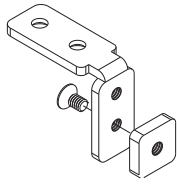

Rail Top Clip A

steel, zinc-plated

Cat No.	2380.57.001
---------	-------------

Packing: 100Pcs per carton

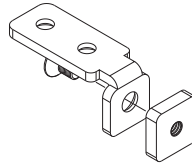

Rail Top Clip B

steel, zinc-plated

Cat No.	2380.57.002
---------	-------------

Packing: 100Pcs per carton

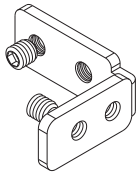

Rail Corner Clip

steel, zinc-plated

Cat No.	2380.57.003
---------	-------------

Packing: 100Pcs per carton

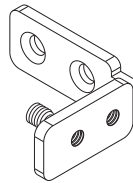

Rail End Clip

steel, zinc-plated

Cat No.	2380.57.004
---------	-------------

Packing: 100Pcs per carton

Aluminium 2×1 Rail End Caps

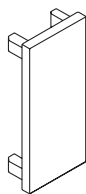

zinc alloy :

Cat No.	Finish
2380. 47. 042	black plated
2380. 41. 042	white, powder coated
2380. 43. 042	chrome-plated,matt

Packing: 100Pcs per carton

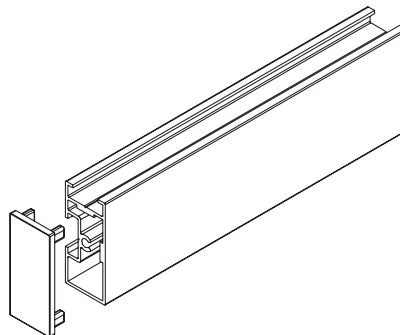

Dimensional Data not binding.
We reserve the right to alter specifications without notice.